



**4096-535**  
**Revision J**

**May 13, 2002**

**ASSEMBLY MANUAL**

# **3.8M C-BAND Rx/Tx ANTENNA SYSTEM**

**SERVSAT COMMUNICATIONS INC**  
**770-754-4547 WWW.SERVSAT.COM**

## 3.8M C-BAND Rx/Tx ANTENNA SYSTEM

<b>J</b>	<b>Revised Added 0168-260 Spacers</b>	<b>10/7/04</b>	
<b>H</b>	<b>Revise Labeling Text</b>	<b>5/13/02</b>	<b>RAH</b>
<b>G</b>	<b>Revised Address</b>	<b>1/22/02</b>	<b>RAH</b>
<b>F</b>	<b>Revise Figure 8 page 29</b>	<b>10-6-00</b>	<b>RAH</b>
<b>E</b>	<b>Revise Part Numbers Page 9</b>	<b>6-21-00</b>	<b>RF</b>
<b>D</b>	<b>Revised to delete Ku-Band features</b>	<b>12-10-98</b>	<b>RF</b>
<b>C</b>	<b>Revised for locations of Labels - ECN2393</b>	<b>09-10-98</b>	<b>PGW</b>
<b>B</b>	<b>Revised Elevation Rod to 0181-187 - ECN2367</b>	<b>04-28-98</b>	<b>PGW</b>
<b>A</b>	<b>Revised pages 11, 14, 16, 18 for clarity</b>	<b>03-17-98</b>	<b>PGW</b>
	<b>- ORIGINAL ISSUE</b>	<b>12/17/97</b>	<b>PGW</b>
	<b>REV. DESCRIPTION</b>	<b>DATE</b>	<b>APPROVED</b>

**3.8 METER C-BAND Rx/Tx ANTENNA SYSTEM****TABLE OF CONTENTS**

<b><u>SECTION</u></b>	<b>TITLE</b>	<b>_____</b>
<b>I</b>	<b>GENERAL</b>	<b>INFORMATION</b>
<b>1.0</b>	<b>INTRODUCTION</b>	
<b>1.1</b>	<b>UNPACKING</b>	<b>AND INSPECTION</b>
<b>1.2</b>	<b>MECHANICAL</b>	<b>INSTALLATION TOOLS</b>
<b>1.3</b>	<b>SITE</b>	<b>SELECTION</b>
<b>II</b>	<b>MAST</b>	<b>AND FOUNDATION</b>
<b>2.0</b>	<b>IN-GROUND</b>	<b>MAST</b>
<b>2.1</b>	<b>PEDESTAL</b>	<b>FOUNDATION</b>
<b>III</b>	<b>REFLECTOR AND SUPPORT ASSEMBLY</b>	
<b>3.0</b>	<b>PART</b>	<b>LIST</b>
<b>3.1</b>	<b>AZ/EL</b>	<b>POSITIONER INSTALLATION</b>
<b>3.2</b>	<b>REFLECTOR</b>	<b>QUADRANT ORIENTATION</b>
<b>3.3</b>	<b>REFLECTOR</b>	<b>SUPPORT ASSEMBLY</b>
<b>IV</b>	<b>FEED</b>	<b>SUPPORT ASSEMBLY</b>
<b>4.0</b>	<b>PART</b>	<b>LIST</b>
<b>4.1</b>		<b>FEED SUPPORT INSTALLATION</b>
<b>4.2</b>		<b>C-BAND CROSS-POL &amp; CO-POL FEEDS</b>
<b>4.3</b>		<b>C-BAND CIRCULAR POLARIZED FEED INST. (1.09 VAR )</b>
<b>4.4</b>		<b>C-BAND CIRCULAR POLARIZED FEED INST. (1.3 VAR )</b>
<b>4.5</b>		<b>C-BAND LNB / LNA ATTACHMENT</b>
<b>V</b>	<b>ANTENNA</b>	<b>POINTING</b>
<b>5.0</b>		<b>ALIGNMENT TO SATELLITE</b>
<b>5.1</b>	<b>INITIAL</b>	<b>ALIGNMENT</b>
<b>VI</b>	<b>MAINTENANCE</b>	
<b>6.0</b>	<b>MAINTENANCE</b>	<b>OVERVIEW</b>
<b>6.1</b>	<b>PERIODIC</b>	<b>INSPECTION</b>
<b>6.2</b>	<b>REFLECTOR</b>	
<b>6.3</b>		<b>MOUNT &amp; REFLECTOR SUPPORT STRUCTURE</b>
<b>6.4</b>		<b>FEED &amp; FEED SUPPORT</b>

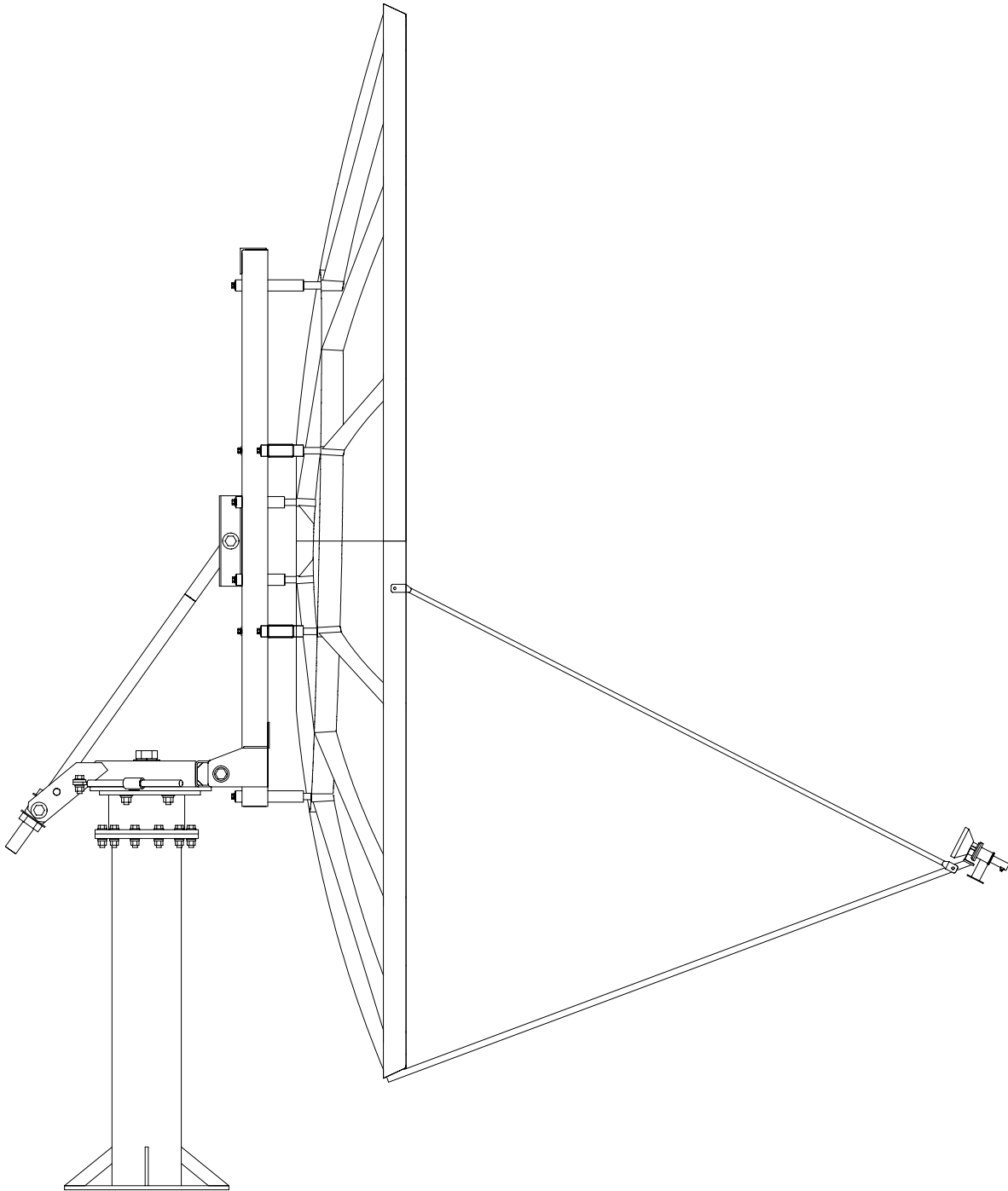

**SECTION I            GENERAL INFORMATION****1.0 INTRODUCTION**

This manual describes the assembly and installation of Prodelin's 3.8M C-Band Rx/Tx antenna system. The Prodelin 3.8M is a rugged, reliable antenna system that will operate at C-band frequencies with high efficiency and at the same time successfully withstand the effects of the environment.

These instructions are listed by sections that cover all areas of assembly and installation. Additional sections are included in the manual to provide information on antenna alignment to the satellite and maintenance.

**1.1 UNPACKING AND INSPECTION**

- 1. UNPACKING & INSPECTION** - The antenna containers should be unpacked and inspected at the earliest date to ensure that all material has been received and is in good condition. A complete packing list for each major component is supplied.

**CAUTION: DO NOT DRAG REFLECTOR SUPPORT FRAME ON THE ADJUSTMENT THREAD RODS AS THESE ARE FACTORY SET AND MUST NOT BE ALTERED!!**

- 2. FREIGHT DAMAGE** - Any damage to materials while in transit should be immediately directed to the freight carrier. He will instruct you on the matters regarding any freight damage claims.
- 3. MATERIAL - MISSING OR DAMAGED** - Any questions regarding missing or damaged materials that is not due to freight carrier should be directed to Prodelin's Customer Service Department at:

**PRODELIN CORPORATION**

**1500 Prodelin Drive**

**Newton NC 28658**

**USA**

**464-4141**

**(828)**

**1.2 MECHANICAL INSTALLATION TOOLS**

HARDWARE SIZE	SAE WRENCH SIZE	METRIC WRENCH SIZE	MAXIMUM REC. TORQUE
1 / 4"	7 / 16"	11 mm	80 in-lbs
5 / 16"	1 / 2"	13 mm	140 in-lbs
3 / 8"	9/16"	14 mm	20 ft-lbs
1 / 2"	3 / 4"	20 mm	45 ft-lbs
3 / 4"	1 – 1 / 8"	28 mm	140 ft-lbs
7 / 8"	1 – 1 / 4"	32 mm	N / A
1"	1 – 1 / 2"	38 mm	220 ft-lbs

Also recommended for installation:

Adjustable Crescent Wrench 10"  
 Ratchet (3 / 8" & 1 / 2" Drive)  
 3" Wrench ( socket, crescent or pipe) for 2" bolt  
 Allen Wrench, 5/32"  
 Screw Driver ( standard and cross blade)  
 Inclinator  
 Compass  
 Step Ladder

**1.3 SITE SELECTION**

In order to achieve maximum performance of your antenna system, it is important to select the correct location for the antenna. The following guidelines should be observed when selecting a site for the installation.

1. The line of site to the satellite should be clear of any obstructions, such as trees or buildings.
2. The site should be relatively flat and level for ease of installation and access to the antenna.
3. The site should be checked for underground obstruction, such as buried cables or pipes.
4. All local building codes should be adhered to (i.e. grounding, foundation requirements, zoning rules, setbacks, etc.).

## SECTION II SUGGESTED MAST AND FOUNDATIONS

**NOTE:** \_\_\_\_\_ Due to the wide variety of soil conditions, Prodelin Corporation does not warrant that any particular design or size of foundation is appropriate for any locality or earth station installation. It is the responsibility of the installer/user to determine if it meets the site/locality requirements. If there is any doubt, have it checked by an architect or structural engineer.

### 2.0 IN-GROUND MAST MOUNT

Figure 1 shows a suggested In-Ground Mast. The pipe is a 15 ft. length of 10" schedule 40. Due to the high cost of shipping, Prodelin recommends site procurement. Note that the Az/EI Positioner Interface is a Slip Flange, which is included with the antenna.

### 2.1 PEDESTAL FOUNDATION

Figure 2 shows a suggested Pad Foundation and figure 3 shows a suggested Pier Foundation. Both foundations utilize Prodelin's Pedestal Mount. To install the Pedestal Mount foundation, follow the steps below.

1. Install one [1] 1-8 hex nut and one [1] 1" flatwasher (items 2,3) onto the anchor rod (item 5), then insert the anchor rod into one of the holes in the plywood template (item 6) and install another 1-8 hex nut and 1" flatwasher. Repeat this procedure for the remaining anchor rods. This will keep all the anchor rods in the straight and proper orientation when the concrete is poured. Next, install two [2] 1-8 hex nuts and one [1] flatwasher (items 2,3) on the other end of each anchor rod. See following pad layout and figures 2 & 3.
2. Once the site location is determined, dig up the area where the foundation will be installed. Be careful not to dig too deep because the soil in the bottom and sides of the foundation should be undisturbed. Position the reinforcing bars as shown. Position the anchor rods so that the flatwashers are positioned under the reinforcing bars. Pour concrete and allow to dry for 24 hours.
3. Once the concrete is dry, remove the plywood template and screw the lower hex nuts as far down on the anchor rods as possible. Then install the mast pipe (item 1) on to the anchor rods. Adjust the lower hex nuts until the mast pipe is level in the vertical position. Reinstall the flatwashers, lockwashers and hex nuts. With the mast pipe tightened down, fill the space between the concrete slab and the mast pipe base with grout.

**IN-GROUND MAST MOUNT**

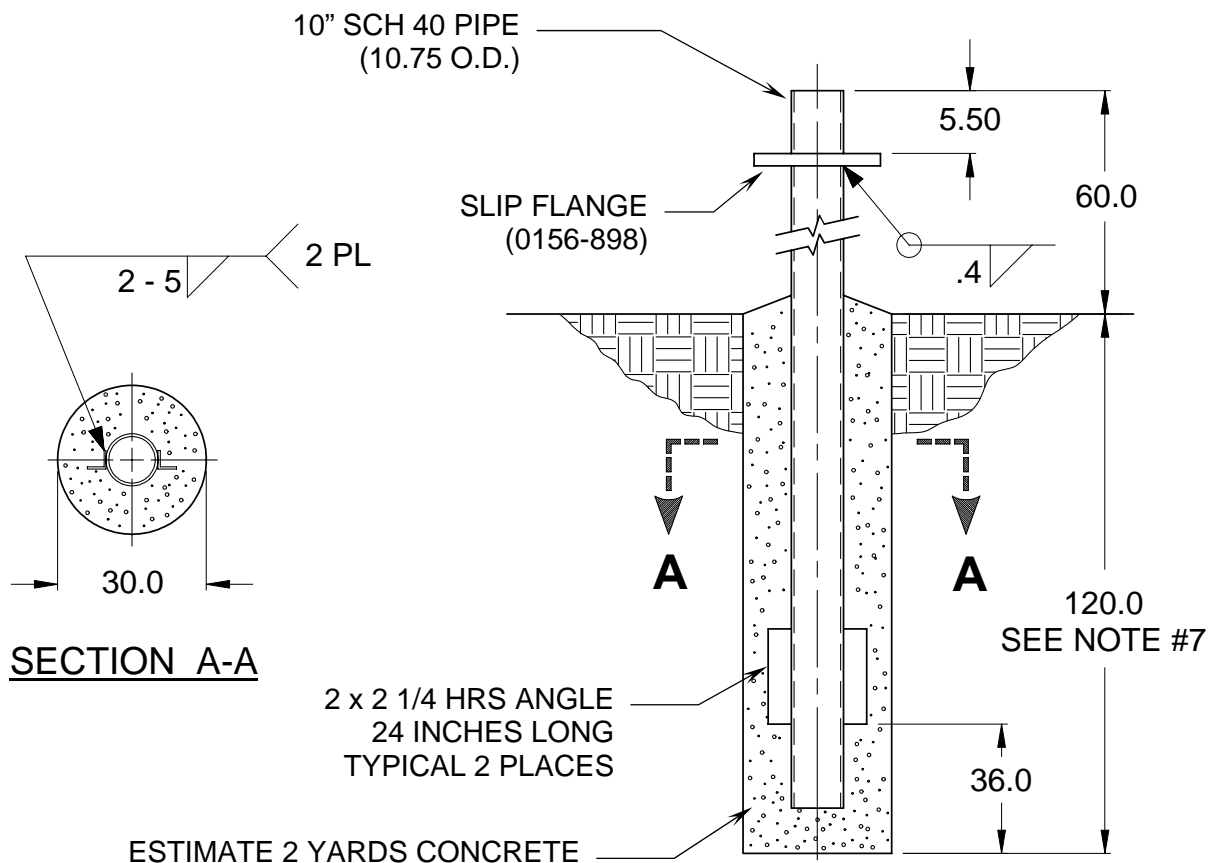

**Figure 1.**

**NOTES:**

1. 2 x 2 x 1/4 HRS ANGLE & 10" SCHEDULE 40 PIPE SHOULD CONFORM WITH ASTM A36 STRUCTURAL STEEL.
2. ALL CONCRETE SHOULD CONFORM TO BUILDING CODE STANDARDS AND HAVE A MINIMUM COMPRESSIVE STRENGTH OF 3000 PSI AT 28 DAYS. (PER ACI-318-77)
3. SOIL BEARING CAPACITY SHOULD BE NO LESS THAN 2000 PSF.
4. CONCRETE SHOULD BE POURED AGAINST UNDISTURBED SOIL.
5. ALLOW CONCRETE 24 HOUR SET TIME BEFORE INSTALLATION OF ANTENNA.
6. THE ANTENNA SHOULD BE PROPERLY GROUNDED TO MEET APPLICABLE LOCAL CODES.
7. MINIMUM DEPTH AS SHOWN OR EXTENDED TO LOCAL FROST LINE.

(PRODELIN CORP. DOES NOT REPRESENT OR WARRANT THAT ANY PARTICULAR DESIGN OR SIZE OF FOUNDATION IS APPROPRIATE FOR ANY LOCALITY OR EARTH STATION INSTALLATION.)



**PEDESTAL FOUNDATIONS**

FOUNDATION PART LIST			
ITEM NO.	PART NO.	DESCRIPTION	QTY
1	0490-285	3.8M PEDESTAL MAST PIPE	1
2	8107-007	1-8 HEX NUT	32
3	8201-049	1" FLATWASHER	24
4	8202-046	1" LOCKWASHER	8
5	0180-238	1 - 8 X 36" ANCHOR ROD	8
6	0274-013	TEMPLATE, PLYWOOD	1

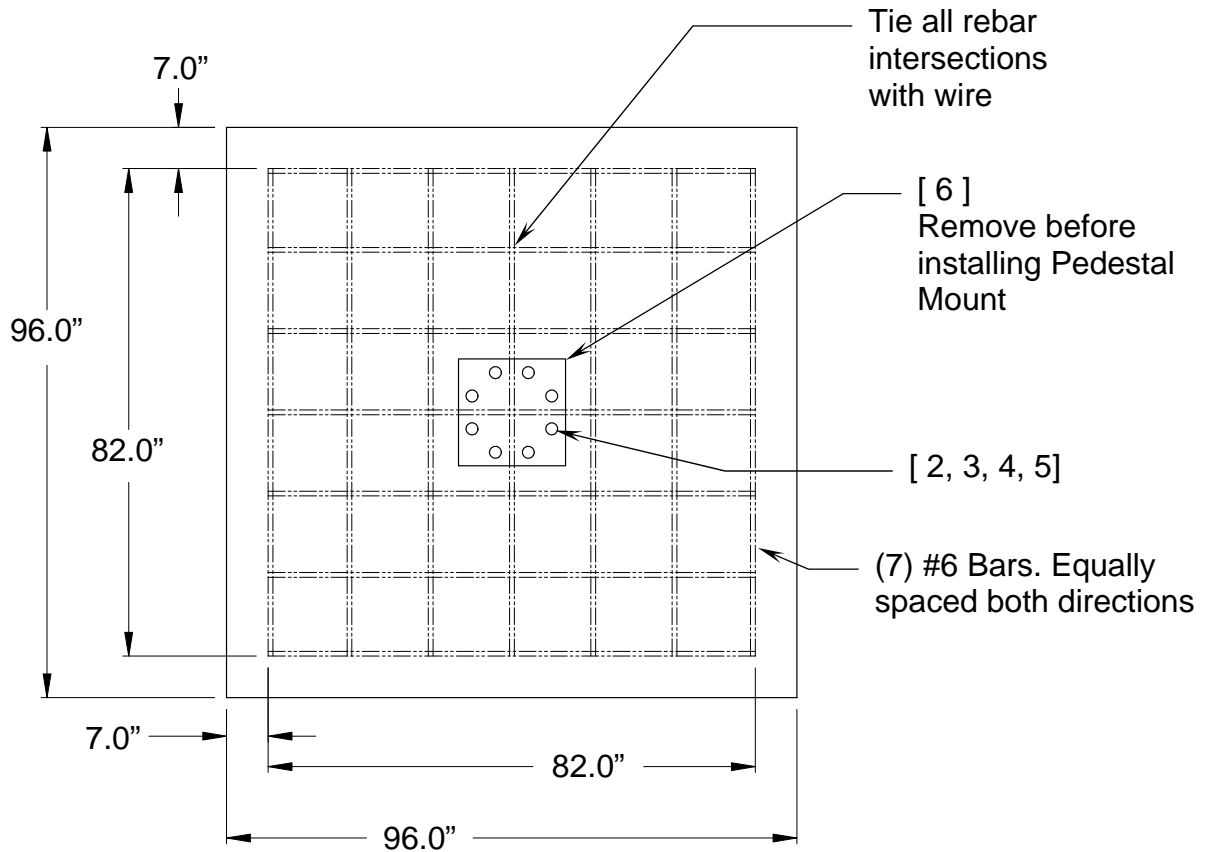

**PAD LAYOUT**

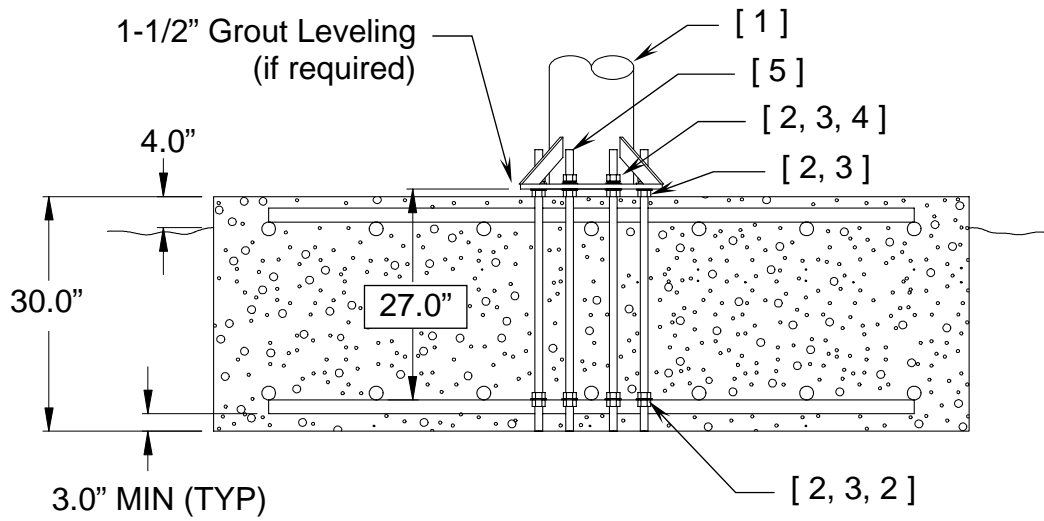

**Figure 2.**

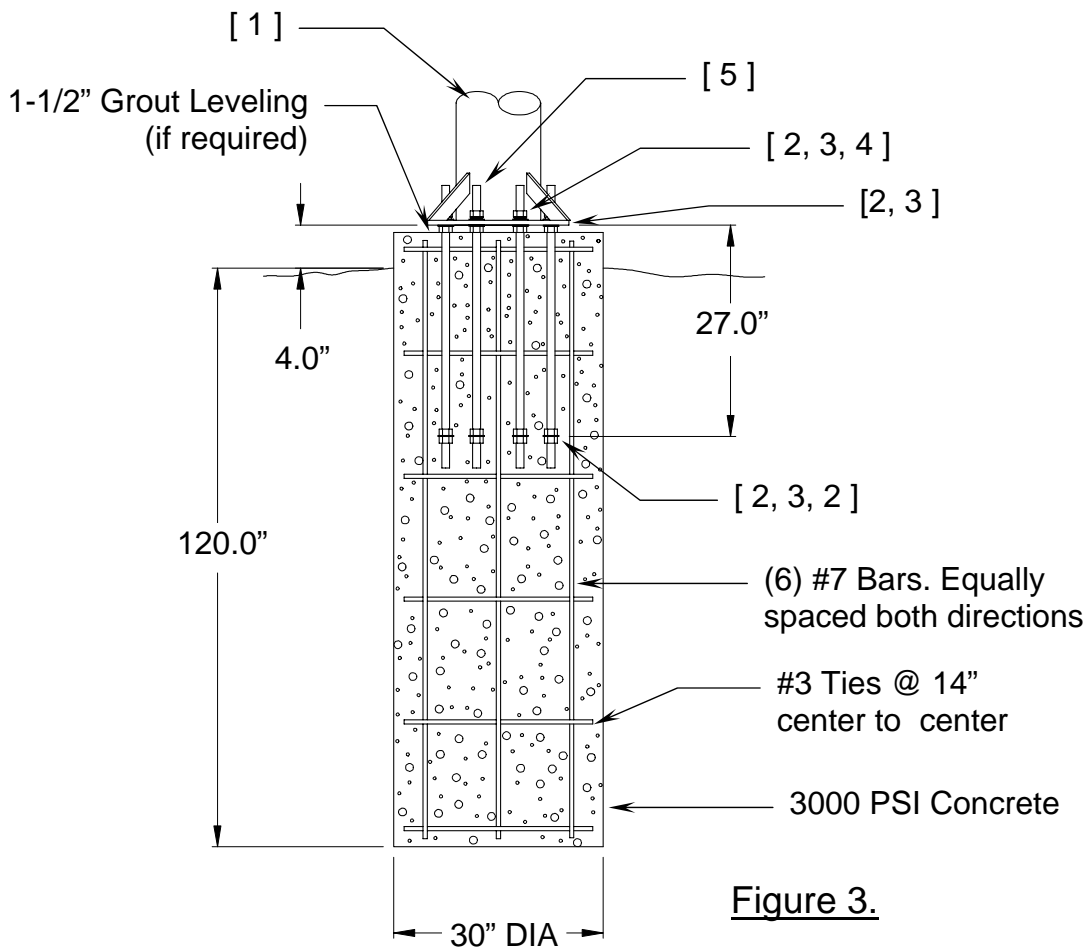

**Figure 3.**

**SECTION III      REFLECTOR AND SUPPORT ASSEMBLY**

<b>REFLECTOR AND SUPPORT ASSEMBLY PART LIST – TABLE 3.0</b>			
<b>ITEM NO.</b>	<b>PART NO.</b>	<b>DESCRIPTION</b>	<b>QTY</b>
1	0159-273	THREADED INSERT - # 1	2
2	0159-272	THREADED INSERT - # 2	2
3	0159-276	THREADED INSERT - # 3	2
4	0159-271	THREADED INSERT - # 4	2
5	0159-275	THREADED INSERT - # 5	2
6	0159-274	THREADED INSERT - # 6	2
7	Varies	REFLECTOR, QUADRANT # 1	1
8	Varies	REFLECTOR, QUADRANT # 2	1
9	Varies	REFLECTOR, QUADRANT # 3	1
10	Varies	REFLECTOR, QUADRANT # 4	1
11	0181-262	Az/EI POSITIONER ASSEMBLY	1
12	0181-485	CROSSARM ASSEMBLY	2
13	0181-486	SUPPORT FRAME ASSEMBLY	1
14	0181-187	ELEVATION ROD ASSEMBLY	1
15	8035-024	BOLT, 3/4 -10 x 3.00	12
16	8201-045	FLATWASHER, 3/4"	24
17	8202-045	LOCKWASHER, 3/4"	12
18	8106-002	NUT, HEX 3/4"	12
19	8201-052	FLATWASHER, 7/8"	12

PART LIST - CONTINUED			
ITEM NO.	PART NO.	DESCRIPTION	QTY
20	8202-052	LOCKWASHER, 7/8"	12
21	8110-007	NUT, HEX 7/8"	12
22	8033-064	BOLT, 1/2 – 13 x 8.00	4
23	8033-072	BOLT, 1/2 – 13 x 9.00	4
24	8033-096	BOLT, 1/2 – 13 x 12.00	4
25	8201-033	FLATWASHER, 1/2"	12
26	8202-043	LOCKWASHER, 1/2"	12
27	0168-260	SPACER, 3.8M REFLECTOR LOCATOR	12
28	8032-014	BOLT, 3/8 – 16 x 1.75	32
29	8201-042	FLATWASHER, 3/8"	64
30	8202-042	LOCKWASHER, 3/8"	32
31	8102-007	NUT, HEX 3/8"	32
32	8036-016	BOLT, 1 – 8 x 2.00	2
33	8036-036	BOLT, 1 – 8 x 4.50	2
34	8036-040	BOLT, 1 – 8 x 5.00	2
35	8201-049	FLATWASHER, 1"	10
36	8202-046	LOCKWASHER, 1"	8
37	8107-007	NUT, HEX 1"	2

**CAUTION:** During the assembly procedure, the sequence of instructions must be followed. ***Do Not Tighten Any Hardware Until Instructed.*** Refer to the antenna assembly parts list and the following steps.

### 3.1 Az/EI POSITIONER INSTALLATION

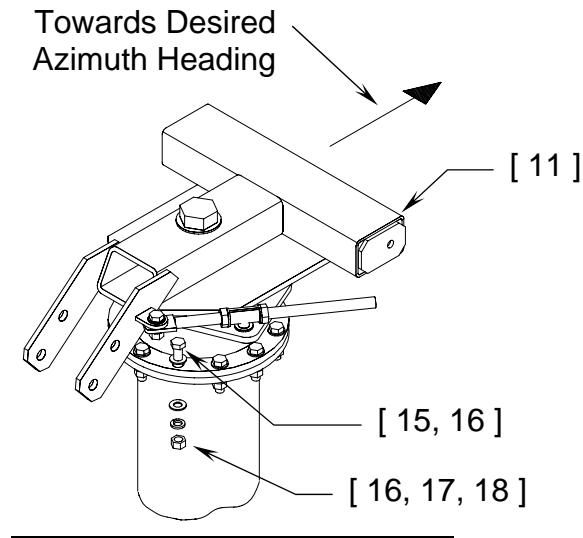

#### STEP 1:

- A) Lift the Az/EI positioner assembly (item 11) on top of the pedestal mast so that it rests upon the slip flange.
- B) Rotate the positioner assembly towards the desired azimuth heading as shown.
- C) Once the position is located, rotate the positioner in either direction to the nearest set of holes. The result is a coarse azimuth setting (+/- 30 deg.). The fine azimuth setting will be set later.
- D) Secure the positioner to the pedestal with 3/4" hardware (items 15,16,17,18). Tighten Securely.

### 3.2 REFLECTOR QUADRANT ORIENTATION

The 3.8M reflector quadrants can be assembled in either the standard or inverted positions. The reflector quadrants are numbered 1, 2, 3 and 4. These numbers can be found on the back of each quadrant embossed into the fiberglass. Note that each quadrant has a longer side (major axis) and a shorter side (minor axis). In the standard upright position, the antenna elevation angle range is between 12 and 90 degrees. When viewed from behind in the standard position (feed support at the bottom), quadrant #1 should be in the upper left; #2 is lower left; #3 is lower right and #4 in the upper right position. See Figure 4.

However, to allow a lower profile installation or in areas of high snow accumulation, the reflector can be assembled in the inverted position (feed support at the top). In this position, quadrant #1 would be in the lower right; #2 upper right; #3 in upper left and #4 in lower left position. See Figure 5.

*Please note* that it is not recommended to invert systems with the Anti-Ice feature. The inverted assembly would prohibit proper heating element location.

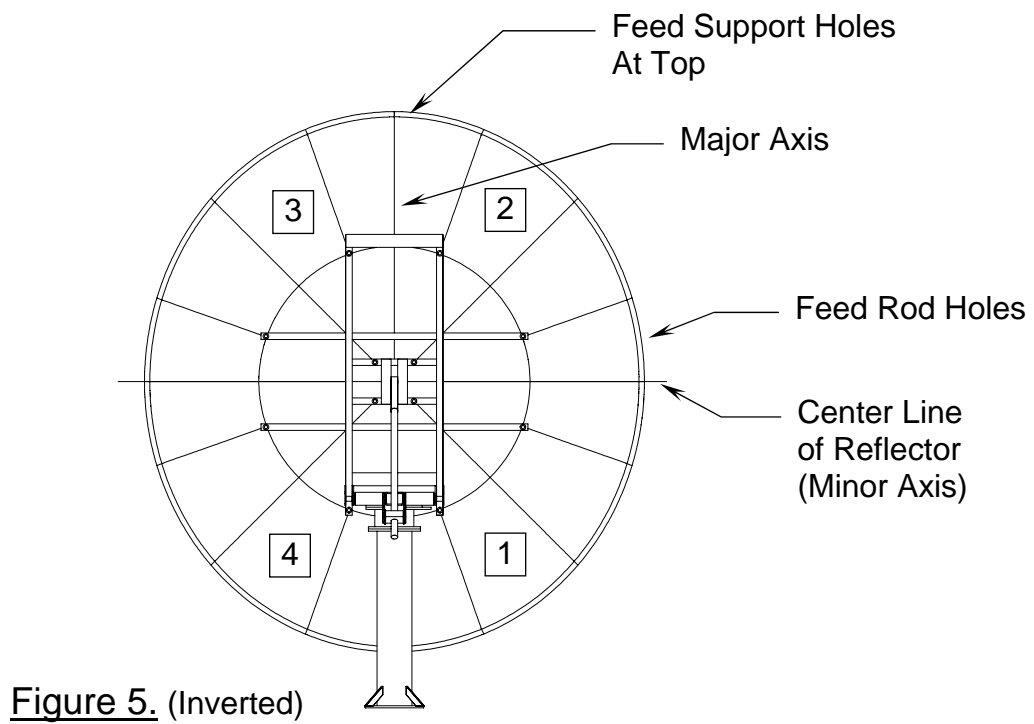
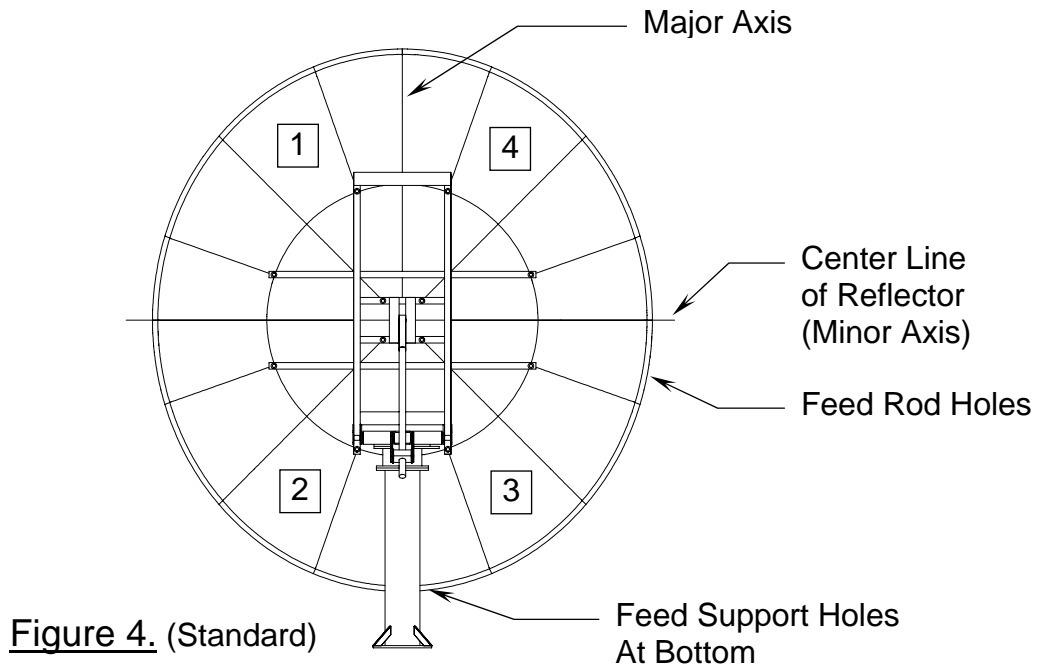

**3.3 REFLECTOR SUPPORT ASSEMBLY**

**WARNING!** The reflector support frame includes a precision alignment feature. Do not drop or drag the frame during the installation process. Do not attempt to adjust the round tube spacers in the frame assembly, as these are factory pre-set. If these spacers are loose or damaged, or there is any obvious damage to the frame, then you must obtain replacement parts for a successful installation.

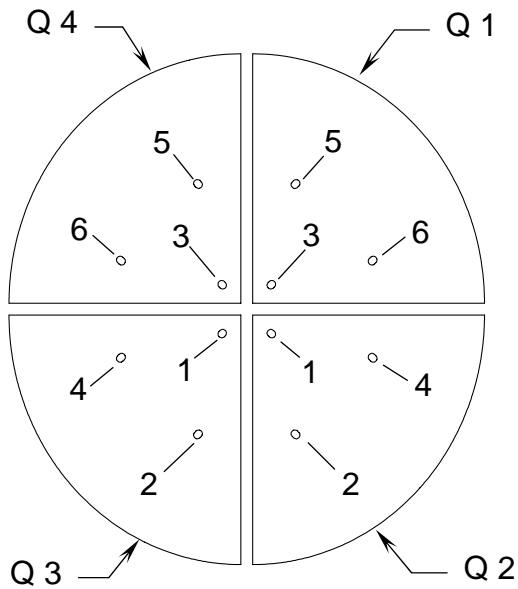

**STEP 1:**

- A) Before beginning antenna assembly. Install 12 threaded inserts (items 1-6) thru the face of each reflector quadrant. Note that there are 6 different insert lengths, 2 of each. Each insert must be in the correct position in each quadrant for correct assembly. The top of each insert is stamped with a insert number ( 1 thru 6). The numbers shown in the illustration correspond with the stamped numbers on the inserts.
- B) Secure inserts with 7/8" hardware ( items 19, 20, 21 ). Snug but do not tighten.

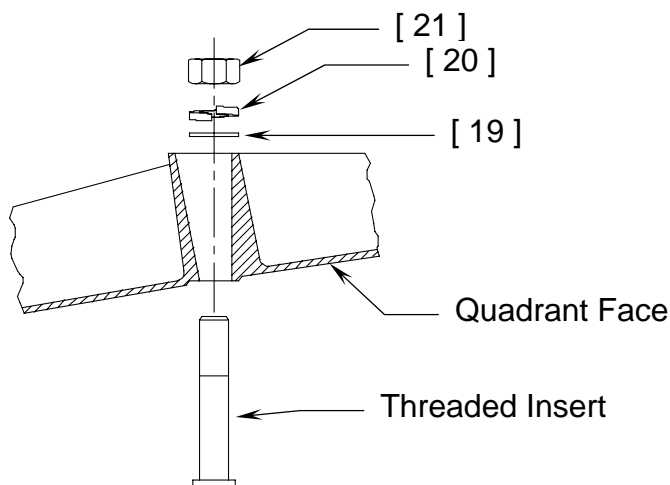

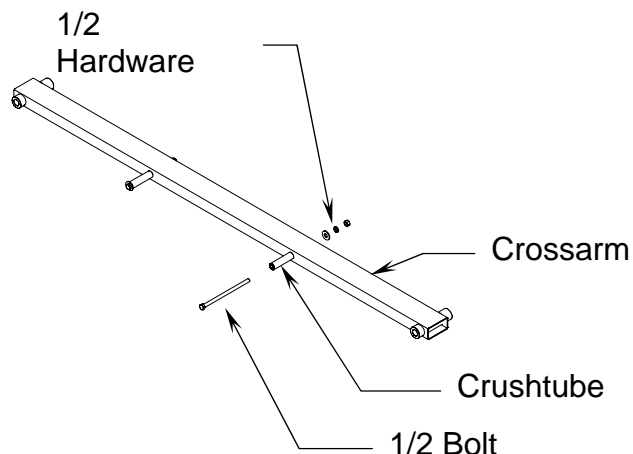

**STEP 2:**

Locate the crossarms ( item 12 ) and remove the 1/2" hardware & anti-crushtubes.

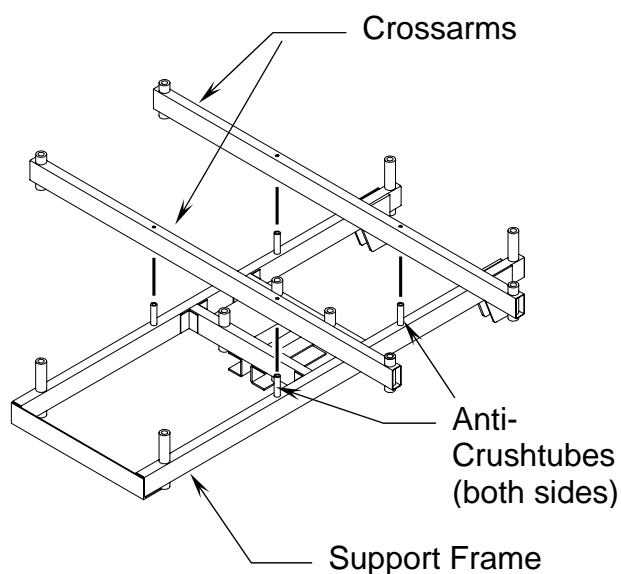

**STEP 3:**

- A) Lay the support frame (item 13) on a safe flat surface, being careful not to damage the tube spacers.
- B) Insert the anti-crushtubes into the 4 holes on the back of the frame as shown.
- C) Place each crossarm over the anti-crushtubes and secure with the 1/2" hardware removed in step 2. Make sure label A of the support frame is located with label A on the crossarm. Repeat procedure with labels B, C and D - See *Detail A*. Tighten securely.

**Note: Hardware should be inserted from crossarm side.**

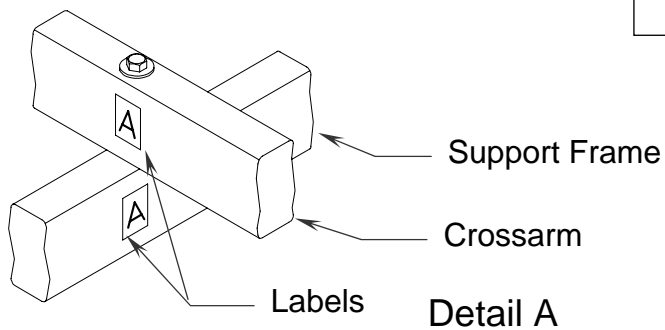



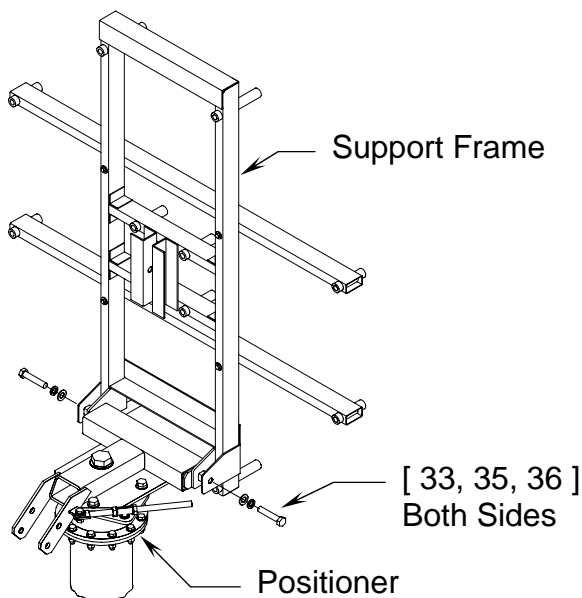

**STEP 4:**

Lift the assembled support frame to the Az/EI positioner and secure with 1" hardware ( items 34, 35, 36 ). Lay frame back to rest on positioner.

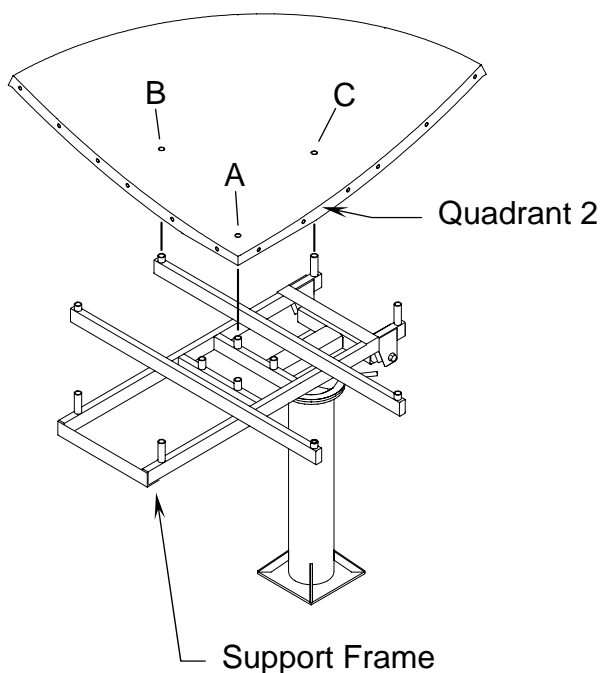

**STEP 5:**

- A) Position quadrant 2 (quadrant 4 for inverted) to the bottom left side of the frame as shown. **Note** that it may be necessary to loosen the 3 reflector inserts to attain the proper alignment with the 3 tubes in the support frame. this procedure may occur with each of the quadrants.
- B) After the quadrant is in position, place a spacer (item 27) between each insert and tube (see Detail B). repeat this procedure for all 4 quadrants.**
- C) Secure the quadrant to the frame with 1/2" hardware (Detail B ). Note that there are 3 different 1/2" bolt lengths:  
 Location A = (items 23, 25, 26)  
 Location B = (items 22, 25, 26)  
 Location C = (items 24, 25, 26)  
 These locations are consistent with all 4 quadrants. Snug hardware only.

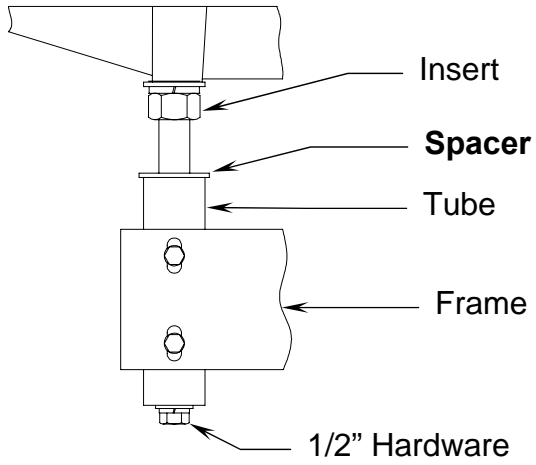

Detail B

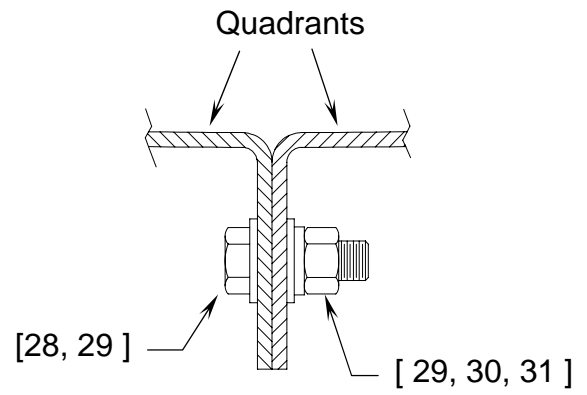

Detail C

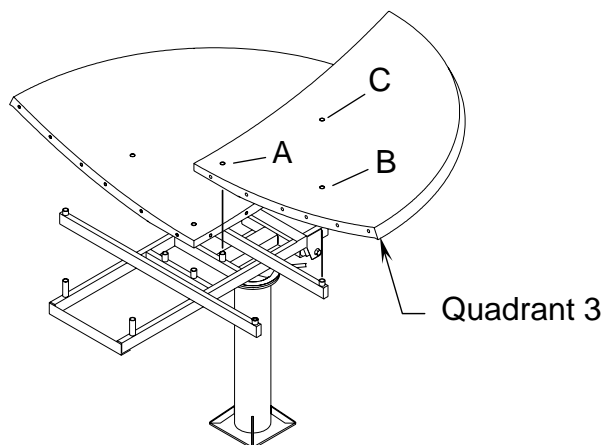

**STEP 6:**

- A) Position quadrant 3 (quadrant 1 for inverted) to the bottom right side of the frame as shown.
- B) Place Spacers as in step 5 and Detail B.**
- C) Secure the quadrant to the frame with 1/2" hardware ( Detail B ). Note that there are 3 different 1/2" bolt lengths:  
Location A = (items 23, 25, 26)  
Location B = (items 22, 25, 26)  
Location C = (items 24, 25, 26)
- D) Secure Quad 2 and 3 together with 3/8" hardware (items 28, 29, 30, 31) See Detail C.

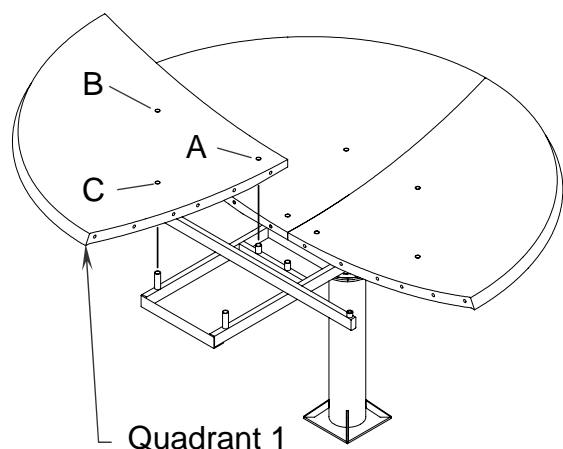

**STEP 7:**

- A) Position quadrant 1 (quadrant 2 for inverted) to the top left side of the frame as shown.
- B) Place Spacers as in step 5 and Detail A.**
- C) Secure the quadrant to the frame with 1/2" hardware ( Detail B ). Note that there are 3 different 1/2" bolt lengths:  
Location A = (items 23, 25, 26)  
Location B = (items 22, 25, 26)  
Location C = (items 24, 25, 26)
- D) Secure Quad 1 and 2 together with 3/8" hardware (items 28, 29, 30, 31) See Detail C.

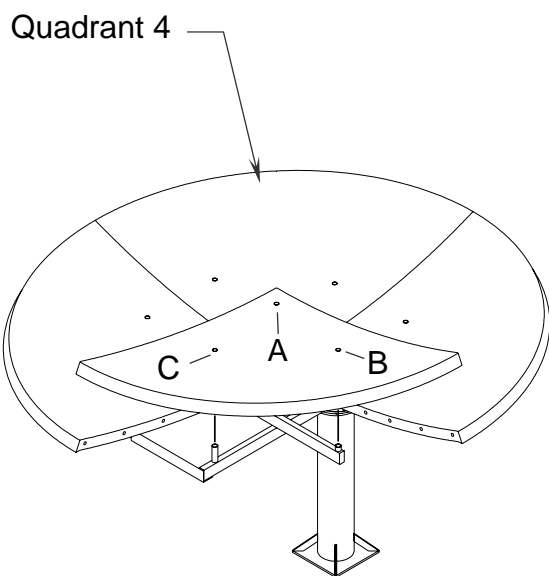

**STEP 8:**

- A) Position quadrant 4 (quadrant 3 for inverted) to the top right side of the frame as shown.
- B) **Place Spacers as in step 5 and Detail A.**
- C) Secure the quadrant to the frame with 1/2" hardware ( Detail B ). Note that there are 3 different 1/2" bolt lengths:  
 Location A = (items 23, 25, 26)  
 Location B = (items 22, 25, 26)  
 Location C = (items 24, 25, 26)
- D) Secure Quad 4 to Quads 1 and 3 with 3/8" hardware (items 28, 29, 30, 31) See Detail C.
- E) At this time tighten all the 1/2", 3/8" and insert hardware alternating from one side of a quadrant to another in a circular pattern starting at the center and working outward. Check the face of

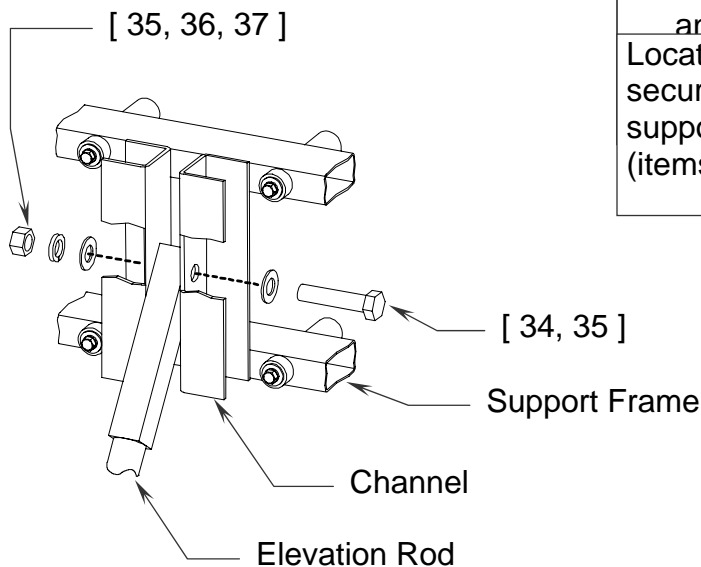

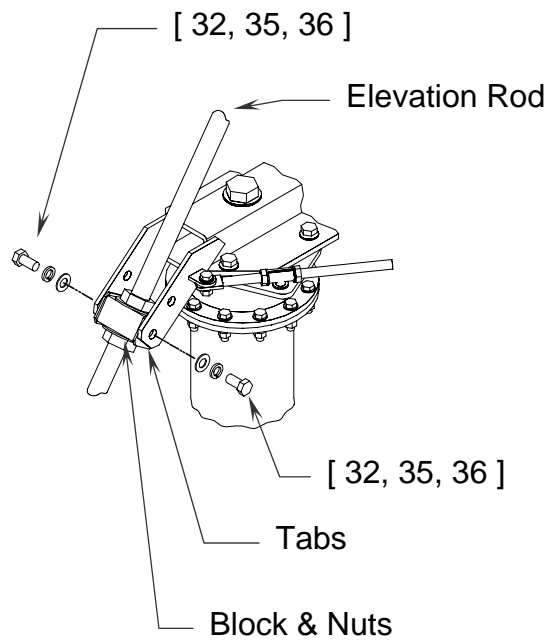
**STEP 10:**

- A) Loosen the nuts on the elevation rod so that the block has some freedom to move.
- B) Lift the support frame and position the block between the tabs on the positioner.
- C) Secure Block with 1" hardware (items 32, 35, 36). Tighten the 2" nuts against the block. Fine elevation adjustment will be set later.

**SECTION IV      FEED SUPPORT ASSEMBLY**

<b>FEED SUPPORT PART LIST – TABLE 4.0</b>			
<b>ITEM #</b>	<b>PART #</b>	<b>DESCRIPTION</b>	<b>QTY</b>
1	0176-257	FEED ROD	2
2	Varies	FEED SUPPORT TUBE	1
3	8033-026	BOLT, 1/2-13 x 3.25"	1
4	8032-012	BOLT, 3/8-16 x 1.50"	4
5	8201-030	FLATWASHER, 1/2"	2
6	8202-043	LOCKWASHER, 1/2"	2
7	8104-007	NUT, HEX, 1/2-13	1
8	8201-042	FLATWASHER, 3/8"	8
9	8202-042	LOCKWASHER 3/8"	4
10	8102-007	NUT HEX 3/8-16	4

**4.1      FEED SUPPORT INSTALLATION**

**STEP 1:**

Attach the long end of each feed rod (item 1) loosely to the sides of the reflector with 3/8" hardware (items 4, 8, 9, 10). See detail D.

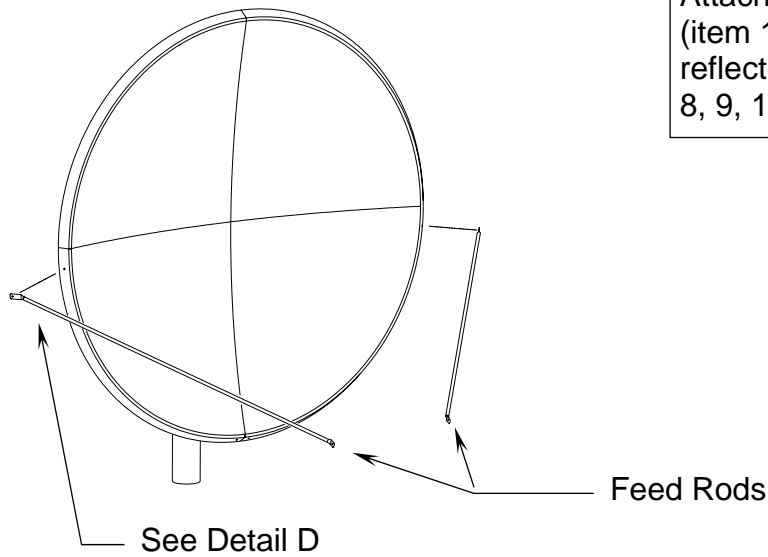

**STEP 2:**

Position the feed support (item 2) in front of the reflector as shown and attach to the to ends of the feed rods with 1/2" hardware (items 3, 5, 6, 7). See Detail E.

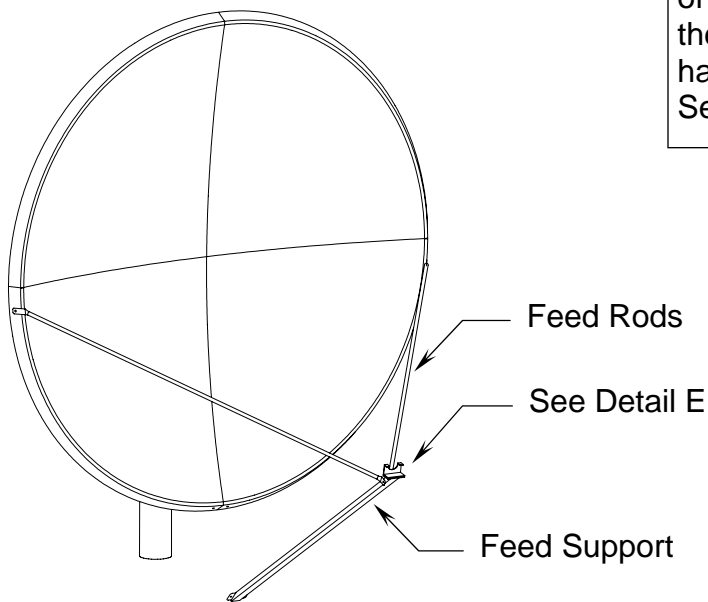

**STEP 3:**

Mount the other end of the feed support along with the feed stabilization brackets and pivot assembly to the bottom of the reflector with 3/8" hardware (items 4, 8, 9, 10). See detail F. Tighten all feed support hardware at this time.

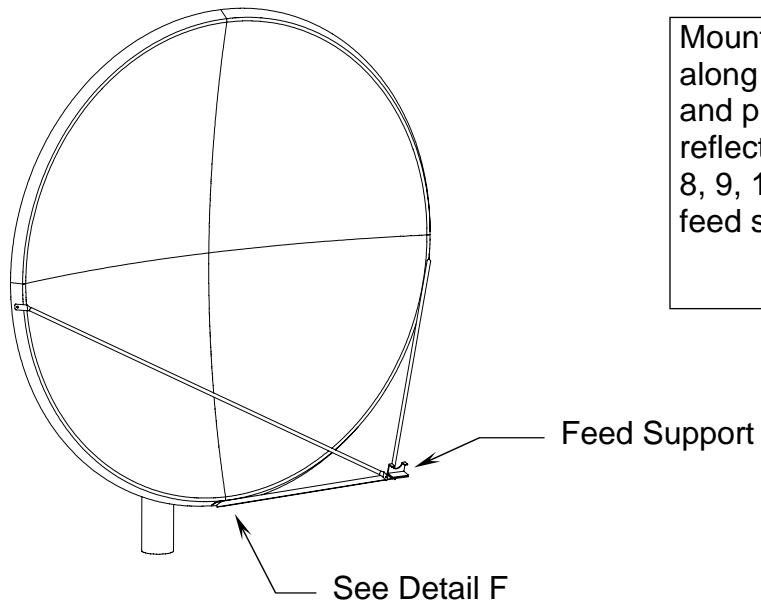



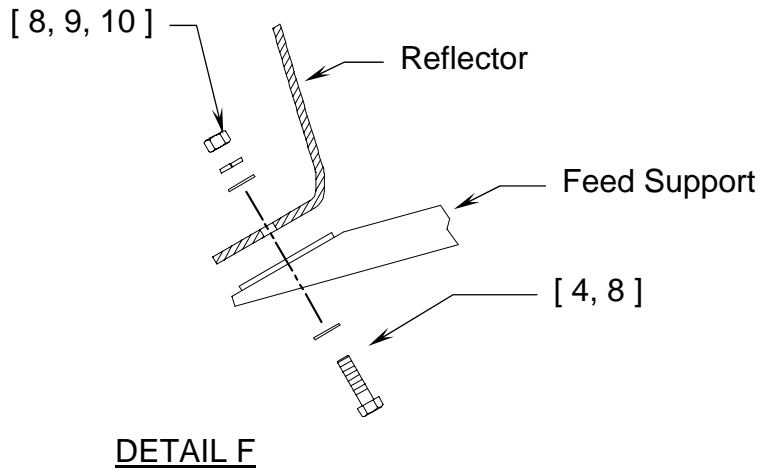
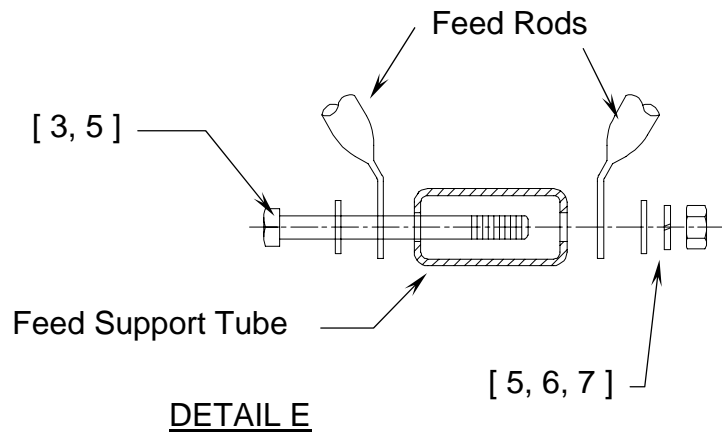
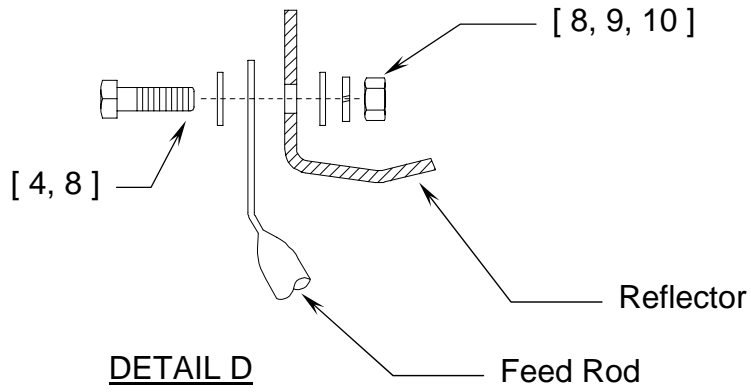

**4.2 C-BAND CROSS-POL AND CO-POL FEEDS**

**Prodelin 3.8m Rx/Tx antenna system is available in Cross-pol, or Co-pol feed assemblies with type "N" or "WR137" connectors. Refer to figure 6, the parts list for this section and follow the instructions in the listed sequence.**

<b>C-BAND CROSS-POL &amp; CO-POL FEED PARTS LIST</b>			
<b>ITEM #</b>	<b>PART #</b>	<b>DESCRIPTION</b>	<b>QTY</b>
1	0800-276	FEED ASSEMBLY, CO-POL, TYPE N	1
	0800-178	FEED ASSEMBLY, CO-POL, TYPE WR137	
	0800-277	FEED ASSEMBLY, CROSS-POL, TYPE N	
	0800-179	FEED ASSEMBLY, CROSS-POL, TYPE WR137	
2	0211-420	FEED MOUNTING BRACKET, BOTTOM	1
3	0211-419	FEED MOUNTING BRACKET, TOP	1
4	8032-010	BOLT, 3/8-16 x 1.25"	4
5	8202-042	LOCKWASHER, 3/8"	4
6	8102-007	NUT, HEX, 3/8-16	4
7	8031-008	BOLT, 5/16-18 x 1.00"	2
8	8202-041	LOCKWASHER, 5/16"	2
9	8101-009	NUT, HEX, 5/16-18	2

1. Attach the bottom feed mounting bracket (item 2) to the feed support tube with four [4] 3/8-16 x 1.25" bolts, four [4] 3/8" lockwashers, and four [4] 3/8-16 hex nuts (items 4,5,6) as shown. Tighten securely.
2. Place the neck of the feed horn into the cradle of the bottom mounting bracket and secure in place by placing the top mounting bracket (item 3) over the neck of the feed horn and fastening with two [2] 5/16-18 x 1.00" bolts, two [2] 5/16" lockwashers and two [2] 5/16-18 hex nuts (items 7,8,9) Tighten securely.

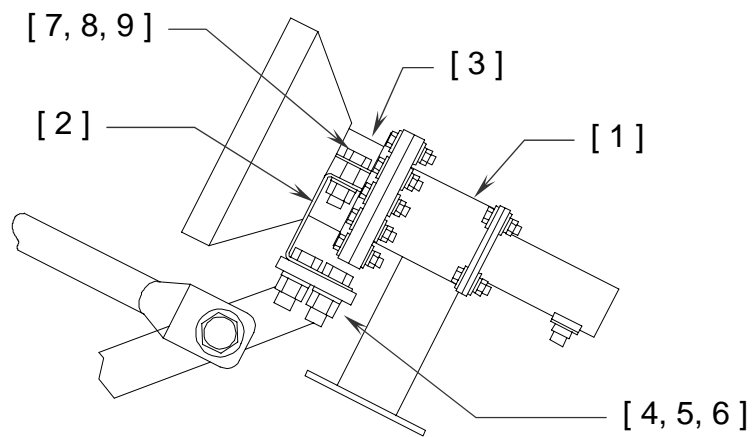

Figure 6

#### 4.3 C-BAND CIRCULAR POLARIZED FEED INSTALLATION ( 1.09 VAR )

**Prodelin 3.8m Rx/Tx antenna system is available in Left Hand or Right Hand Circular Polarized feed assemblies with type "N" or "WR137" connectors.**

*Note that the sense of polarization is relative to the transmit band of the feed assembly and not the antenna system. For instance, a left hand circular polarized feed assembly will transmit a left hand polarized signal which will strike the reflector and be reversed to a right hand uplink to the satellite. The feed is factory assembled for testing purposes but can be switched from left hand to right hand or vice versa in the field if necessary. To switch, remove the eight screws holding the OMT to the polarizer, rotate the OMT 90° so that the arrow on the OMT flange aligns with the correct marking on the polarizer flange (LHCP or RHCP), and replace the eight screws. Tighten securely.*

<b>C-BAND CIRCULAR POLARIZED FEED PART LIST ( 1.09 VAR )</b>			
<b>ITEM #</b>	<b>PART #</b>	<b>DESCRIPTION</b>	<b>QTY</b>
1	0183-383	FEED ASSEMBLY, TYPE "N", L.H.	1
	0183-384	FEED ASSEMBLY, TYPE "N", R.H.	
	0183-385	FEED ASSEMBLY, TYPE "WR137", L.H.	
	0183-386	FEED ASSEMBLY, TYPE "WR137", R.H.	
2	0181-805	FEED MOUNTING BRACKET	1
3	0188-172	FEED HORN TOP CLAMP	1
4	0188-174	CIRCULAR POL TOP CLAMP	1
5	8031-008	BOLT, 5/16-18 x 1.00"	2
6	8202-041	LOCKWASHER, 5/16"	2
7	8101-009	NUT, HEX, 5/16-18	2
8	8201-041	FLATWASHER, 5/16"	4
9	8030-022	BOLT, 1/4-20 x 3.00	2
10	8030-020	BOLT, 1/4-20 x 2.50	2
11	8202-040	LOCKWASHER, 1/4"	4
12	8201-040	FLATWASHER, 1/4"	4

Refer to the part list and figure 7 for this section. Follow the instructions in the listed sequence. Do not tighten any hardware until instructed.

1. Place feed mounting bracket (item 2) on the feed support and attach with 5/16-18 x 1.00 bolts, flatwashers, lockwashers and hex nuts (items 5,6,7,8). Tighten securely. Note that the smaller opening (2.75" dia) is for the feed horn and should be pointed towards the reflector.
2. Place the feed assembly (item 1) into the cradle of the feed mounting bracket and secure by placing the feed horn top clamp (item 3) in position and secure with (2) 1/4-20 x 2.50 bolts, lockwashers and flatwashers (items 10, 11, 12). Tighten securely.
3. Place the circular polarizer top clamp in place and secure with (2) 1/4-20 x 3.00 bolts, lockwashers and flatwashers ( items 9, 11, 12 ). Tighten securely. The antenna system is now ready to be aligned to the satellite.

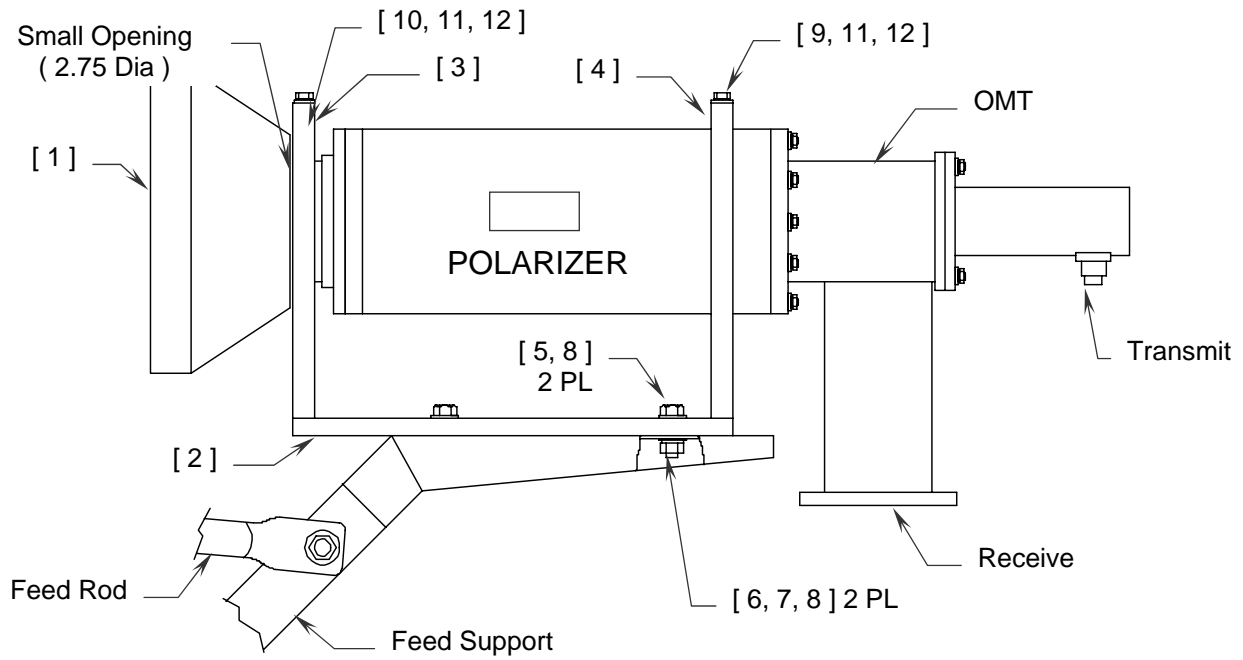

**Figure 7**

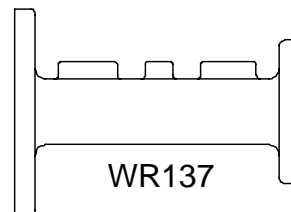

**4.4 C-BAND CIRCULAR POLARIZED FEED INSTALLATION ( 1.3 VAR )**

<b>C-BAND CIRCULAR POLARIZED FEED ASM PART LIST (1.3 VAR)</b>			
<b>ITEM NO.</b>	<b>PART NO.</b>	<b>DESCRIPTION</b>	<b>QTY</b>
1	0183-317	FEED HORN	1
2	0183-341	CROSS-POL OMT	1
3	0182-191	CIRCULAR POLARIZER	1
4	0211-420	FEED MOUNTING BRACKET	2
5	0211-419	FEED MOUNTING BRACKET -TOP	2
6	0181-689	CIRCULAR POLARIZER BRACKET	1
7	0198-124	O-RING	2
8	8302-007	#10-24 X 1.25 SCREW	16
9	8202-032	#10 LOCKWASHER	16
10	8111-005	#10-24 HEX NUT	16
11	8201-037	#10 FLATWASHER	32
12	8032-008	3/8-16 X 1.00 BOLT	4
13	8032-010	3/8-16 X 1.25 BOLT	4
14	8202-042	3/8" LOCKWASHER	8
15	8102-007	3/8-16 HEX NUT	8
16	8031-008	5/16-18 X 1.00 BOLT	2
17	8031-012	5/16-18 X 1.50 BOLT	2
18	8031-014	5/16-18 X 1.75 BOLT	2
19	8202-009	5/16" LOCKWASHER	7
20	8101-009	5/16-18 HEX NUT	7
21	8201-041	5/16" FLATWASHER	4

Refer to the part list and figure 8 for this section. Follow the instructions in the listed sequence. Do not tighten any hardware until instructed.

1. Apply silicone grease to [2] o-rings (item 7) and place [1] in the o-ring groove in the circular polarizer (item 3). Attach the feed horn (item 1) to the circular polarizer (end with the o-ring) with [8] #10 x 1.25 screws, [16] flatwashers, [8] lockwashers and [8] #10 hex nuts (items 8,9,10,11). Tighten securely. **Note:** *The screws should be inserted from the feed horn side to prevent any interference.*

2. Bolt the OMT (item 2) to the circular polarizer by placing the remaining o-ring in the groove of the OMT and fastening it to the circular polarizer with [8] #10 x 1.25 screws, [16] flatwashers, [8] lockwashers and [8] #10 hex nuts (items 8,9,10,11).  
**Note:** *The screws should be inserted from the circular polarizer side to prevent interference.* For left hand polarization, align the "LHCP" on the flange of the circular polarizer with the arrow on the OMT. For right hand polarization, align the "RHCP" with the arrow on the OMT. Tighten securely. **Note:** *when a polarization setting is attempted, installers should keep in mind that right hand and left hand polarization refers to the transmission of signals from the feed to the reflector. Then the reflector reverses signal. Therefore, a "LHCP" feed system results in an antenna system that transmits a Right Hand Circular Polarized signal.*
3. Attach [1] bottom feed mounting bracket (item 4) and the circular polarizer bracket (item 60 to the feed support tube plate with [4] 3/8 x 1.25 bolts, [4] lockwashers and [4] hex nuts (items 13, 14, 15) through the feed mounting bracket, circular polarizer and feed support as shown, and [2] 5/16 x 1.75 bolt, [2] lockwasher, [4] flatwasher and [2] hex nut (items 18,19,20,21 through the circular polarizer bracket and feed support tube only. Tighten securely
4. Attach the remaining bottom feed mounting bracket (item 4) to the circular polarizer bracket with [4] 3/8 x 1.00 bolts, [4] lockwashers and [4] hex nuts (items 12, 14, 15). Do not tighten.
5. Place the feed assembly from step #1 into the brackets and secure by fastening [1] top feed mounting bracket (item 5) over the neck of the feed horn with [2] 5/16 x 1.00 bolts, [2] lockwashers and [2] hex nuts (items 16,19,20). Fasten the remaining top feed mounting bracket (item 5) over the neck of the circular polarizer with [2] 5/16 x 1.50 bolts, [2] lockwashers and [2] hex nuts (items 17,19,20). Tighten the feed mounting bracket (from step #4) to the circular polarizer bracket. The antenna system is now ready to be aligned to the satellite.

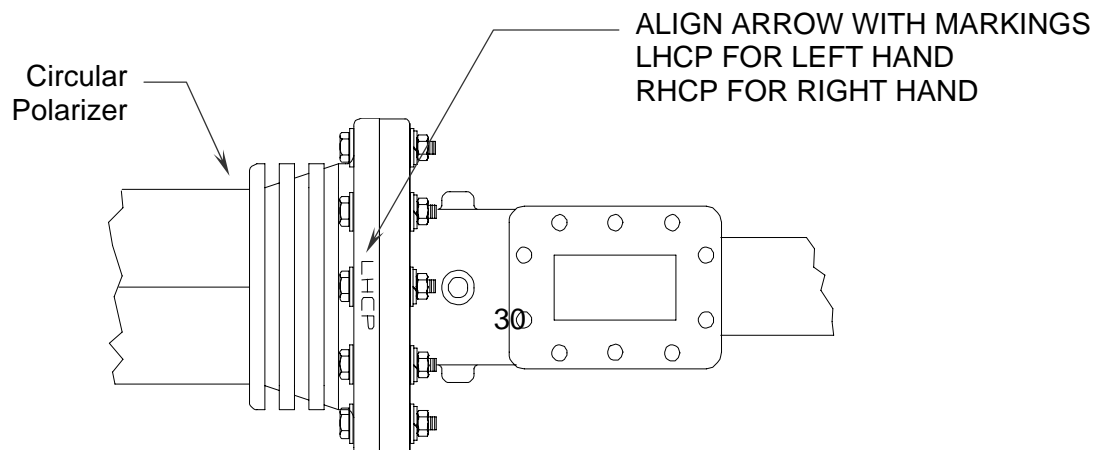



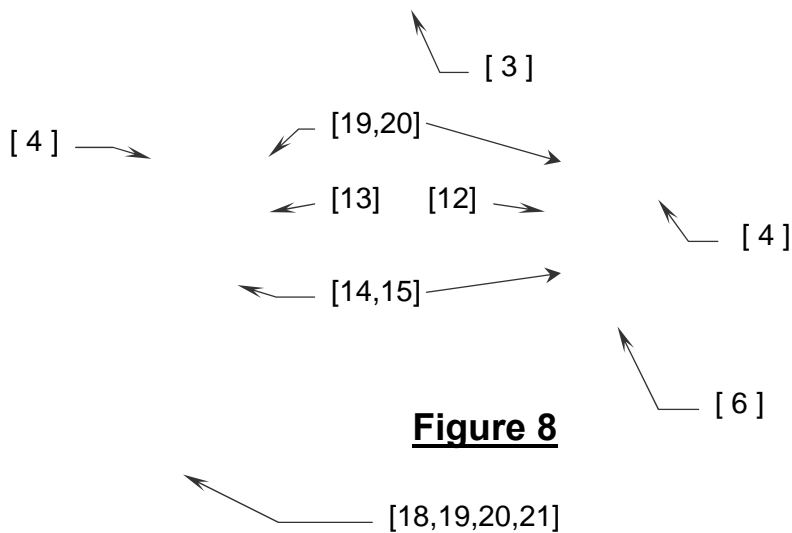
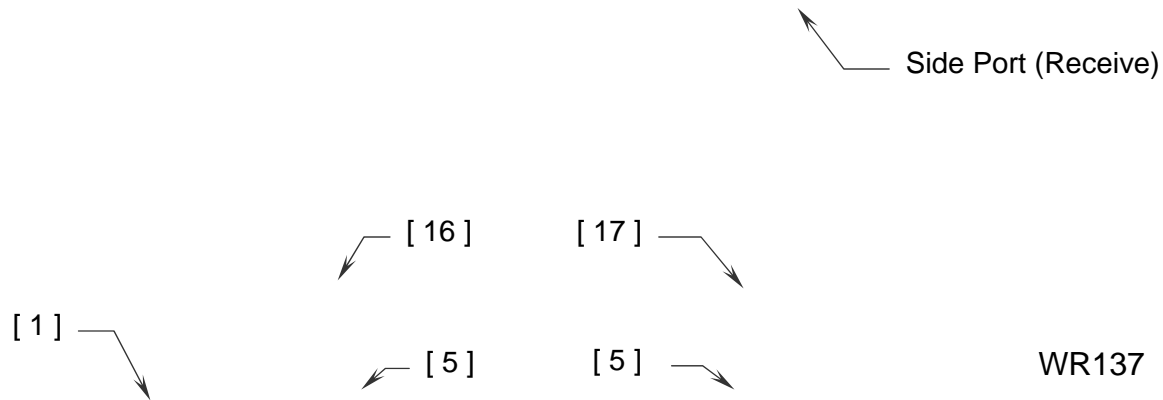

**Figure 8**

**4.5 C-BAND LNB/LNA ATTACHMENT**

1. Apply silicone grease to gasket (item#1) and place gasket in groove in flange of LNA/LNB (customer supplied), as shown below in figure 9.
2. Attach LNA/LNB to side port (Rx) flange of OMT with (10) 1/4-20 x 1.00" bolts, (10) 1/4" flatwashers, (10) 1/4" lockwashers, and (10) 1/4-20 hex nuts (items 2,3,4,5).

3. Tighten 1/4" hardware securely.

PARTS LIST - C-BAND LNB/LNA ATTACHMENT			
ITEM #	PART #	DESCRIPTION	QTY
1	0171-073	GASKET, CPR WR2296 FLANGE HALF-THICK	1
2	8023-008	BOLT, 1/4-20 X 1.00" TYPE 304 S.S. STD.	10
3	8201--036	FLATWASHER, 1/4" S.S. STD.	10
4	8202-031	LOCKWASHER, 1/4" S.S. STD.	10
5	8100-005	NUT, HEX, 1/4-20 S.S. STD.	10

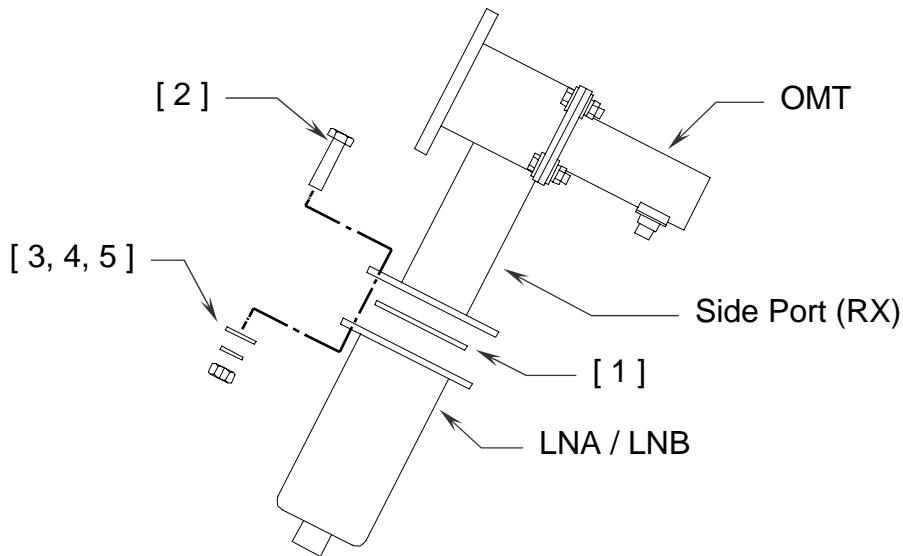

Figure 9

**SECTION V      ANTENNA POINTING****5.0      ALIGNMENT TO SATELLITE**

Prodelin recommends that the 3.8 meter Az/EI mount be positioned to the satellite orbital arc by a trained or experienced installer. The instructions in section 5.1 are intended as an overview of the alignment procedure.

**5.1      INITIAL ALIGNMENT**

The 3.8 meter offset reflector contains a 22.62° elevation offset look angle. Therefore, when the reflector aperture is perpendicular to the ground, the antenna is actually looking 22.62° in elevation.

1. Raise the antenna by turning the 2" nuts on the elevation rod assembly.
2. After the correct elevation angle is set, rotate the antenna in azimuth by loosening the 2" nut on top of the positioner and removing the 1" hardware (4 places) in the positioner plate, refer to figure 10.
3. At this time rotate the antenna in azimuth by turning the 1" nuts located at the azimuth adjustment tube. Rotate azimuth until a signal is reached.
4. Peak the antenna by fine adjustments made in both the elevation and the azimuth.
5. Adjust polarization by rotating the feed assembly in its mounting bracket.
6. Re-install the 1" hardware in the Az/EI positioner (form step# 2) and tighten all adjustment hardware securely.

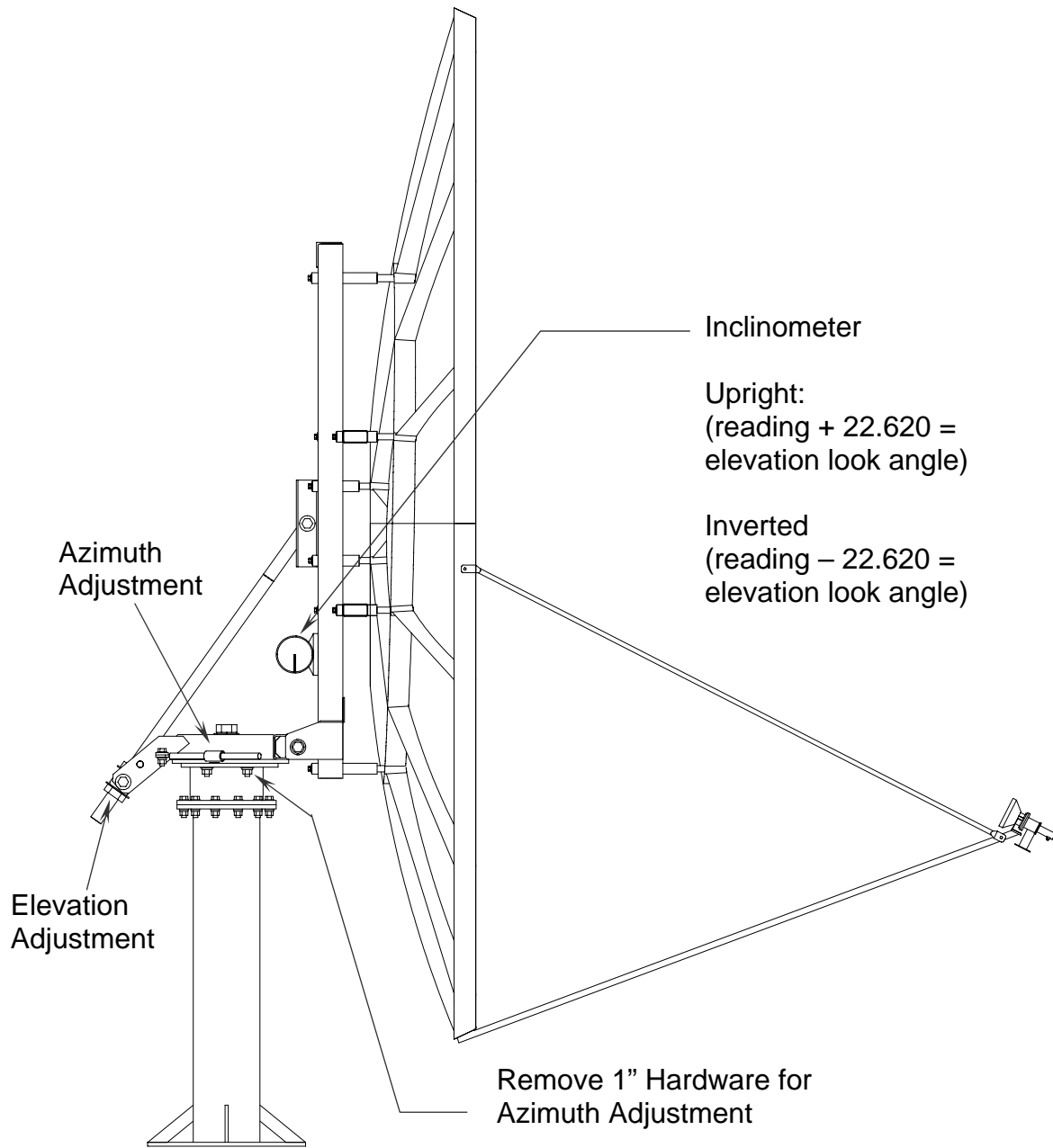

Figure 10

## SECTION VI        MAINTENANCE

### 6.0 MAINTENANCE OVERVIEW

After installation, the antenna requires only periodic inspection. It is anticipated that maintenance, if required will be minimal and easily handled by a local or in house maintenance staff. The materials used in the construction of this Earth Station Antenna virtually eliminate any maintenance repairs.

### 6.1 PERIODIC    INSPECTION

It is suggested that a periodic inspection be performed at least every six months.

**NOTE:**        **After any very severe weather condition, inspection of the antenna should be performed to determine if foreign objects have caused damage or if survival specification have been exceeded.**

This inspection should include the following:

- 1:    Check all bolting locations - all bolts should be tight.
- 2:    Check all structural members - repair or replace if damaged.
- 3:    Check the foundation anchor bolts - they must be secure and have no failure signs in the foundation.
- 4:    Check for corrosion - on the reflector structure and the mount.

### 6.2 REFLECTOR

Prodelin's reflector does not require any maintenance. The composite construction of the reflector is virtually impervious to any damages that could be caused by weather or other atmospheric conditions.

It is only necessary to inspect for any physical damage done by vandalism or very severe weather conditions.

Should any damage be detected to a portion of the reflector, contact the Customer Service Department at Prodelin for recommendation involving reflector repair.

### **6.3 MOUNT AND REFLECTOR SUPPORT STRUCTURE**

The mount and reflector support structure supplied with this antenna is of steel construction and has a galvanized finish with zinc w/ultraguard finish for hardware.

If inspection shows any sign of structural failure, the mount members that are damaged should be repaired or replaced.

Corrosion: Any corrosion on steel members may be repaired with a cold, zinc rich galvanizing paint.

### **6.4 FEED AND FEED SUPPORT**

The feed support tube and feed rods should be inspected to insure that all hardware is secure. The feed and radio mounting bolts should be tight.

The feed horn window should be inspected to insure that it is intact so that no moisture can collect inside the feed horn. Replace if damaged.