

Type 125: 1.2m Rx/Tx Class I Antenna

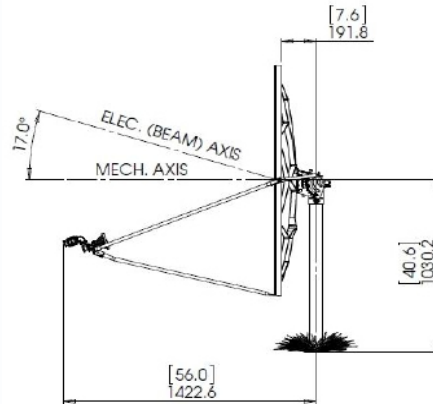

- ISO 9001:2008 Certificate of Registration
- One-piece precision SMC Reflector
- Precision Az/EI Mount
- Fine Azimuth and Elevation Adjustment Features
- All Materials Comply with EU Directive No. 2002/95/EC (RoHS)



- 720 Hour Salt Spray Hardware
- Standard Waveguide Flange

The Skyware Global 1.2m Rx/Tx Class I Antenna is a rugged, commercial quality product suitable for the most demanding applications.

- The reflector is constructed from glass fiber reinforced polyester [SMC] for strength and accuracy. A proprietary process developed by Skyware Global ensures high RF reflectivity as needed for Ku-Band operation.
- The precision Az/EI mount is made of galvanized steel for excellent corrosion resistance. This mount includes special features to increase pointing accuracy with low backlash and lockdown error.
- This Az/EI allows the antenna to be installed on standard 73-76mm [2⁷/₈" - 3"] OD installation mounts.
- All hardware is plated to 720 hour salt spray standards under ASTM B-117.
- Cross-Polarization Isolation of 30dB on axis.
- Excellent Tx Port-to-Port Isolation of 90dB or better.
- Meets or exceeds regulator agency requirements.
- Class I system designed for typical lightweight Ku-band RF Electronics.*

* 2.0 kg or 4.5 lb max. weight (For BUC and LNB) 2.2 kg or 4.8 lb max. weight (For Transceiver)



• PRODUCT SPECIFICATIONS

1.2m Rx/Tx Class I Antenna

RF Performance

Operating Frequency
 TX*13.75-14.50GHz
 RX10.70-12.75GHz

Polarization
Linear Orthogonal
(Co-Pol Optional)

Gain (±0.3 dB)
 TX 43.3 dBi @ 14.3GHz
 RX 41.8 dBi @ 12.0GHz

3 dB Beamwidth
 TX1.2° @ 14.3GHz
 RX 1.5° @ 12.0GHz

Sidelobe Envelope (Tx, Co-Pol dBi)
 1.5° < θ < 20°29-25 log θ dBi
 20° < θ < 26.3° -3.5 dBi
 26.3° < θ < 48°32-25 log θ dBi
 48° < θ < 180° -10 dBi (Typical)

Antenna Cross-Polarization*
 >30 dB within 1 dB Contour

Antenna Noise Temperature
 10° EL 45K
 20° EL 31K
 30° EL 24K

VSWR
 TX1.3:1 Max
 RX 1.5:1 Max

Isolation**(Port to Port)
 TX 90 dB
 RX 40 dB

Feed Interface
 TX WR75 Flat Flange
 RX WR75 Flat Flange

(All specifications typical)
 (*Eutelsat Approval and Cross-Polarization
 Specification apply
 to Tx band 14.0-14.5 GHz only.)
 (** With Skyware Global OMT/Filter)

Mechanical Performance

Reflector Material. Glass Fiber Reinforced Composite

Antenna OpticsOne-Piece Offset Feed Prime Focus

Mount Type Elevation Over Azimuth

Elevation Adjustment Range 5°-90° Continuous
 Fine Adjustment

Azimuth Adjustment Range 360° Continuous
 ± 5° Fine Adjustment

Mast Size27⁸/₈" - 3"
 (73-76mm) Diameter

Environmental Performance

Wind Loading
 Operational. 72km/h (45 mph)

Functional Survival 128m/h (80 mph)

Ultimate Survival. 200km/h (125 mph)

Survival Temperature. -50°C to +80°C

Operational Temperature -40°C to +55°C

Humidity. 0 to 100% (Condensing)

Atmosphere. Standard Hardware 720 Hrs
 SST Requirements (ASTM B-117)

Solar Radiation 360 BTU/h/ft²

Shock and Vibration. As Encountered during
 Shipping and handling



Satcom solutions for the long haul



REV 03/15-02
 Page 2 of 2